

干涉圖 / Allowable cutting capacity

CLT-63-12T

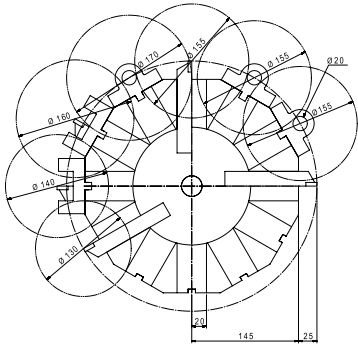

CLT-80-12T

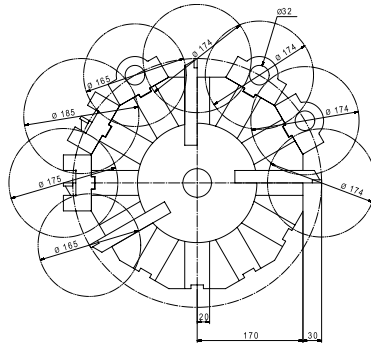

CLT-100-12T

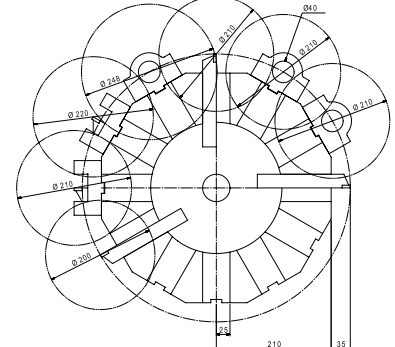

CLT-160-8T

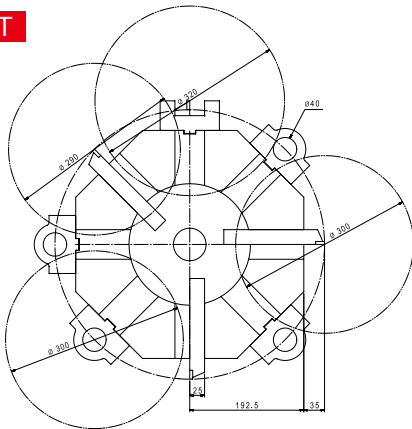

CLT-200-8T

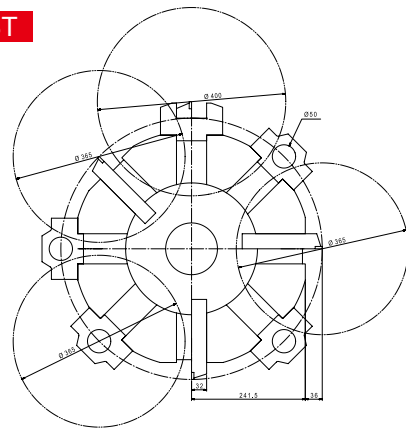

CLT-63-8T

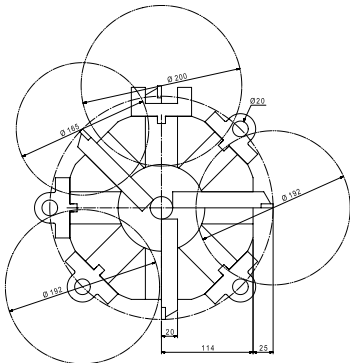

CLT-80-8T

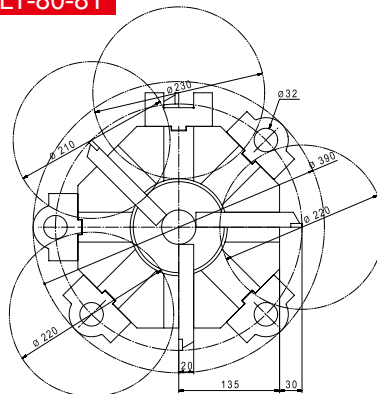

CLT-100-8T

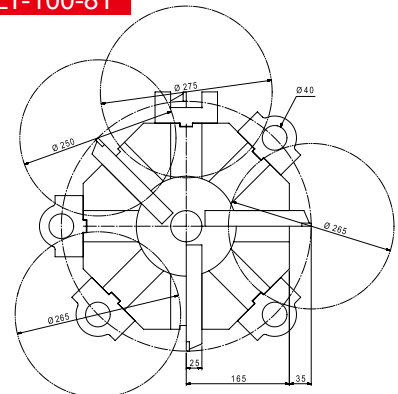



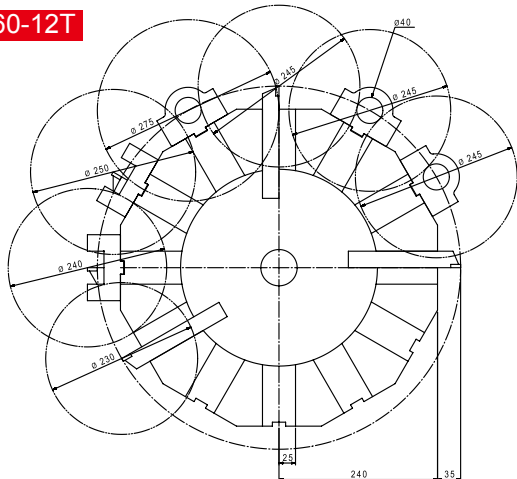

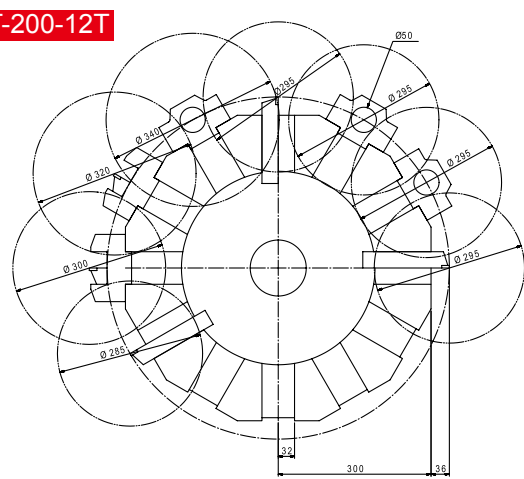

CLT-160-12T



CLT-200-12T

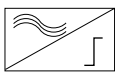

CLT-63, 80, 100,125,200,300

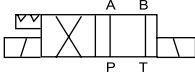
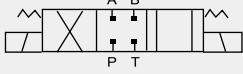
| 項次 Item | 內容 Article | 特性 Specification | 線碼 Cable code | 信號 Signal |
|----------|---|---|--|---|
| Sensor A | 刀位檢出感測器 Position Sensor | 10~30V DC 100 mA (負載 Load) 輸出 Output-PNP-NO |  -24V -A -0 | 棕 24V Brown 24V 黑 信號 Black Out 藍 0V Blue 0V |
| Sensor B | 刀位檢出感測器 Position Sensor | 10~30V DC 100 mA (負載 Load) 輸出 Output-PNP-NO |  -24V -B -0 | 棕 24V Brown 24V 黑 信號 Black Out 藍 0V Blue 0V |
| Sensor C | 刀位檢出感測器 Position Sensor | 10~30V DC 100 mA (負載 Load) 輸出 Output-PNP-NO |  -24V -C -0 | 棕 24V Brown 24V 黑 信號 Black Out 藍 0V Blue 0V |
| Sensor D | 刀位檢出感測器 Position Sensor | 10~30V DC 100 mA (負載 Load) 輸出 Output-PNP-NO |  -24V -D -0 | 棕 24V Brown 24V 黑 信號 Black Out 藍 0V Blue 0V |
| Sensor E | 刀盤停止轉動檢出感測器 Disk sensor | 10~30V DC 100 mA (負載 Load) 輸出 Output-PNP-NO |  -24V -E -0 | 棕 24V Brown 24V 黑 信號 Black Out 藍 0V Blue 0V |
| Sensor F | 刀盤鬆開鎖緊檢出感測器 Disk unclamp sensor | 10~30V DC 100 mA (負載 Load) 輸出 Output-PNP-NO |  -24V -F -0 | 棕 24V Brown 24V 黑 信號 Black Out 藍 0V Blue 0V |
| Sol A | 刀盤鬆開電磁閥 Disk clamp(unclamp) solenoid | DC24V AC110V |  | |
| Sol B | 刀盤正反轉電磁閥 Disk rotation solenoid | DC24V AC110V |  | |